



晶采光電科技股份有限公司
AMPIRE CO., LTD.

SPECIFICATIONS FOR LCD MODULE

CUSTOMER	
CUSTOMER PART NO.	
AMPIRE PART NO.	AC-162AYILY-528(R)
APPROVED BY	
DATE	

- Preliminary Specification
 Formal Specification

AMPIRE CO., LTD.

**4F., No.116, Sec. 1, Xintai 5th Rd., Xizhi Dist., New Taipei
City221, Taiwan (R.O.C.)**

新北市汐止區新台五路一段 116 號 4 樓(東方科學園區 A 棟)

TEL:886-2-26967269 , FAX:886-2-26967196 or 26967270

Approved by	Checked by	Organized by
<i>Patrick</i>	<i>Mark</i>	<i>Tank</i>

*This specification is subject to change without notice.

RECORD OF REVISION

Revision Date	Page	Contents	Editor
2021/09/28	--	New Release	Tank

1 FEATURES

- (1) Display format : 16 characters × 2 lines
- (2) Construction: LCD panel, Bezel, Zebra, Yellow-green LED back-light and PCB.
- (3) Display type: STN, Yellow-green, Transflective, 6 o'clock view.
- (4) Controller: ST7066U-0A or Equivalent.
- (5) + 3.3V power input for logic circuit. Built-in DC/DC converter for LCD driving.
- (6) Normal temperature type.
- (7) Excellent IC: VOP maintains at 5V for whole temp. Range, no need extra temp. Compensation circuit.
- (8) ROHS compliant.

2 MECHANICAL DATA

Parameter	Stand Value	Unit
Dot size	0.55(W) × 0.65(H)	mm
Dot pitch	0.60(W) × 0.70(H)	mm
Character size	2.95(W) × 5.55(H)	mm
Viewing area	64.0(W) × 17.2(H)	mm
Module size	85.0(W) × 29.5(H) × 10.0 max (T)	mm

3 ABSOLUTE MAXIMUM RATINGS

Parameter		Symbol	Min	Max	Unit
Logic Circuit Supply Voltage		VDD-VSS	-0.3	7.0	V
LCD Driving Voltage		VDD-VO	-0.3	10.0	V
Input Voltage		V _I	-0.3	VDD+0.3	V
Normal temp. type	Operating Temp.	T _{OP}	0	50	°C
	Storage Temp.	T _{STG}	-20	70	°C

4 ELECTRO-OPTICAL CHARACTERISTICS

Parameter	Symbol	Condition	Min	Typ.	Max	Unit	Note
----- Electronic Characteristics -----							
Logic Circuit Supply Voltage	VDD-VSS	--	2.7	3.3	5.5	V	
LCD Driving Voltage (STN)	VDD-VO	0 °C	4.75	5.0	5.25	V	0 ~ 50 °C for Normal Temp. type
		25 °C	4.75	5.0	5.25		
		50 °C	4.75	5.0	5.25		
Input Voltage	VIH	--	0.7VDD	--	VDD	V	
	VIL	--	VSS	--	0.3VDD	V	
Logic Supply Current	IDD	VDD=3.3V	--	1.5	2.3	mA	
----- Optical Characteristics (STN) -----							
Contrast	CR	25°C	--	5	--		Note 1
Rise Time	tr	25°C	--	80	120	ms	Note 2
Fall Time	tf	25°C	--	150	300	ms	
Viewing Angle Range	θ f	25°C & CR≥2	--	35	--	Deg.	Note 3
	θ b		--	30	--		
	θ l		--	30	--		
	θ r		--	30	--		
Frame Frequency	fF	25°C	--	64	--	Hz	
-----Array type LED Back-light Characteristics -----							
Parameter	Symbol	Condition	Min	Typ	Max	Unit	Note
Forward Voltage	VF	--	--	4.05	4.3	V	Supply Voltage between A&K
Forward Current	IF	VF=4.05V	--	120	--	mA	
LCM Luminous intensity		VF=4.05V	--	30	--	cd/m ²	

* LED Dice number = 2×12=24

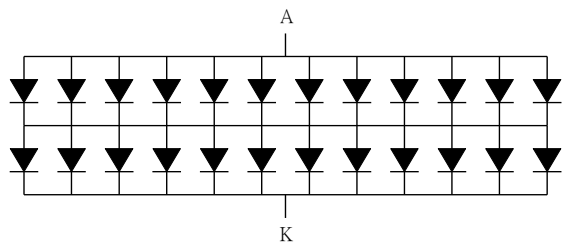

(NOTE 1) Contrast Ratio:

$$CR = (\text{Brightness in OFF state}) / (\text{Brightness in ON state})$$

(NOTE 2) Response Time:

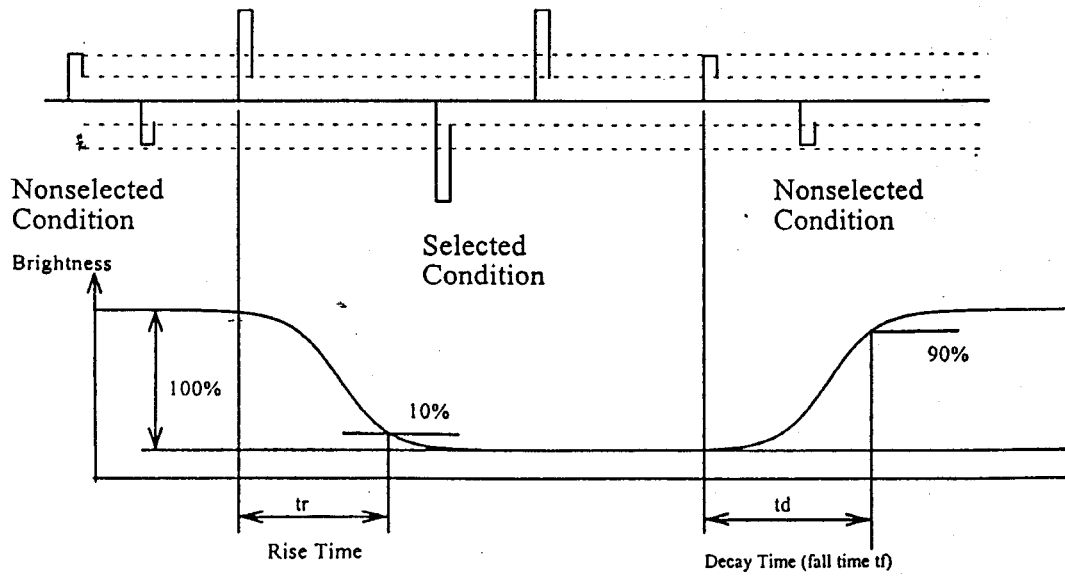

(NOTE 3) Viewing Angle:

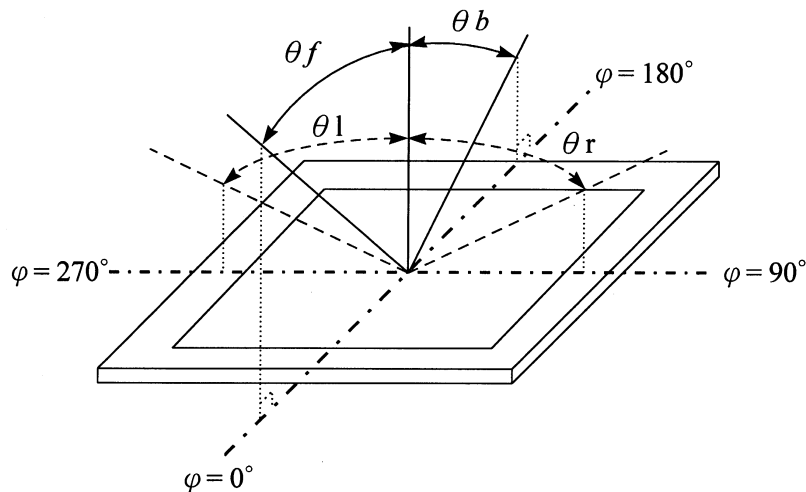

5 BLOCK DIAGRAM & INTERFACE

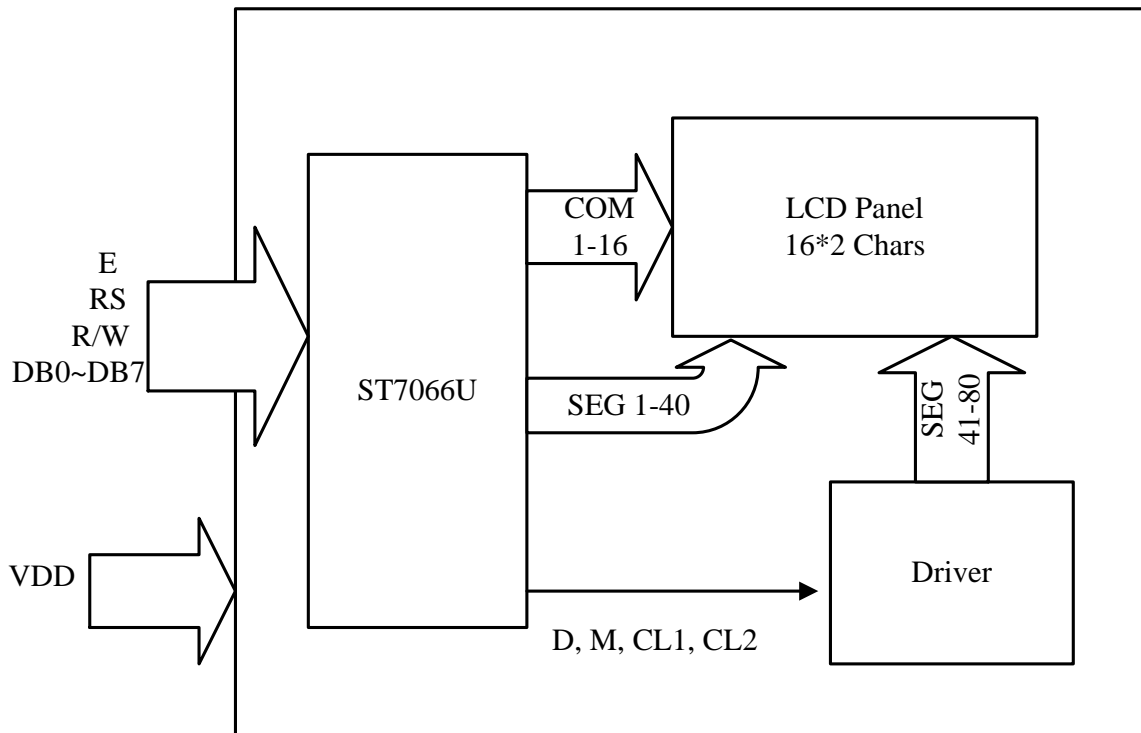

No.	Symbol	Function
1	VDD	Supply Voltage for Logic (+3.3V)
2	VSS	Ground (0V)
3	VO	Contrast Adjust
4	RS	Data/Instruction Select
5	R/W	Read/Write Select
6	E	Enable Signal
7	DB0	Data Bus
8	DB1	Data Bus
9	DB2	Data Bus
10	DB3	Data Bus
11	DB4	Data Bus
12	DB5	Data Bus
13	DB6	Data Bus
14	DB7	Data Bus

6 POWER SUPPLY

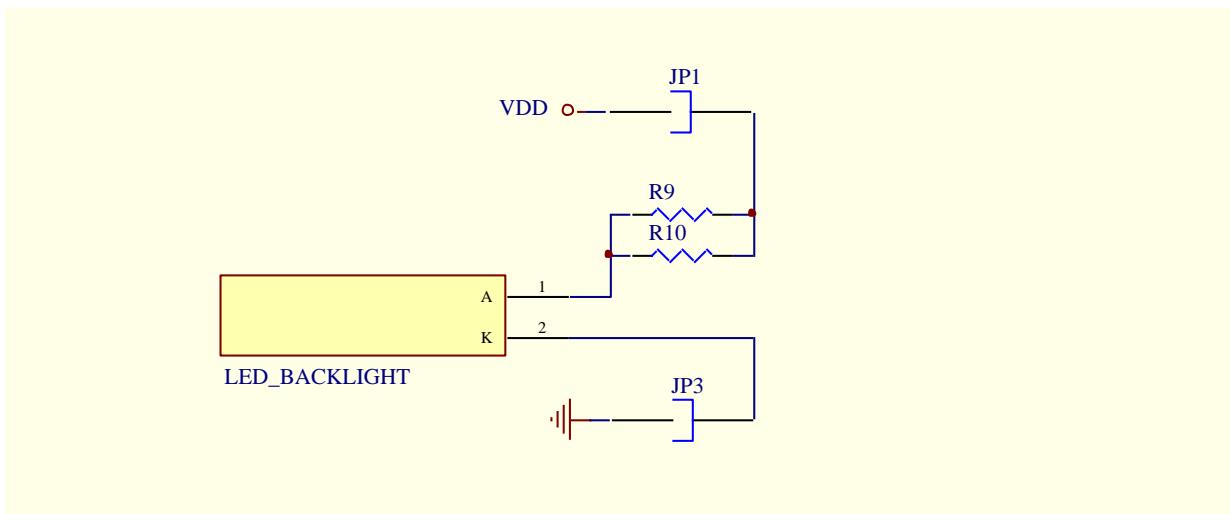
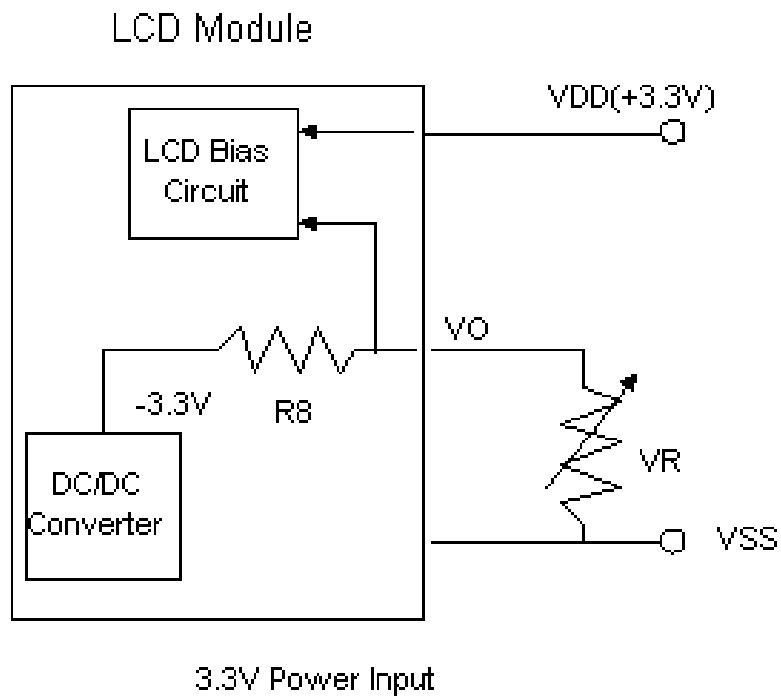

Add +4.05V between LED A & K directly. (Default)

7 TIMING CHARACTERISTICS

Write Operation

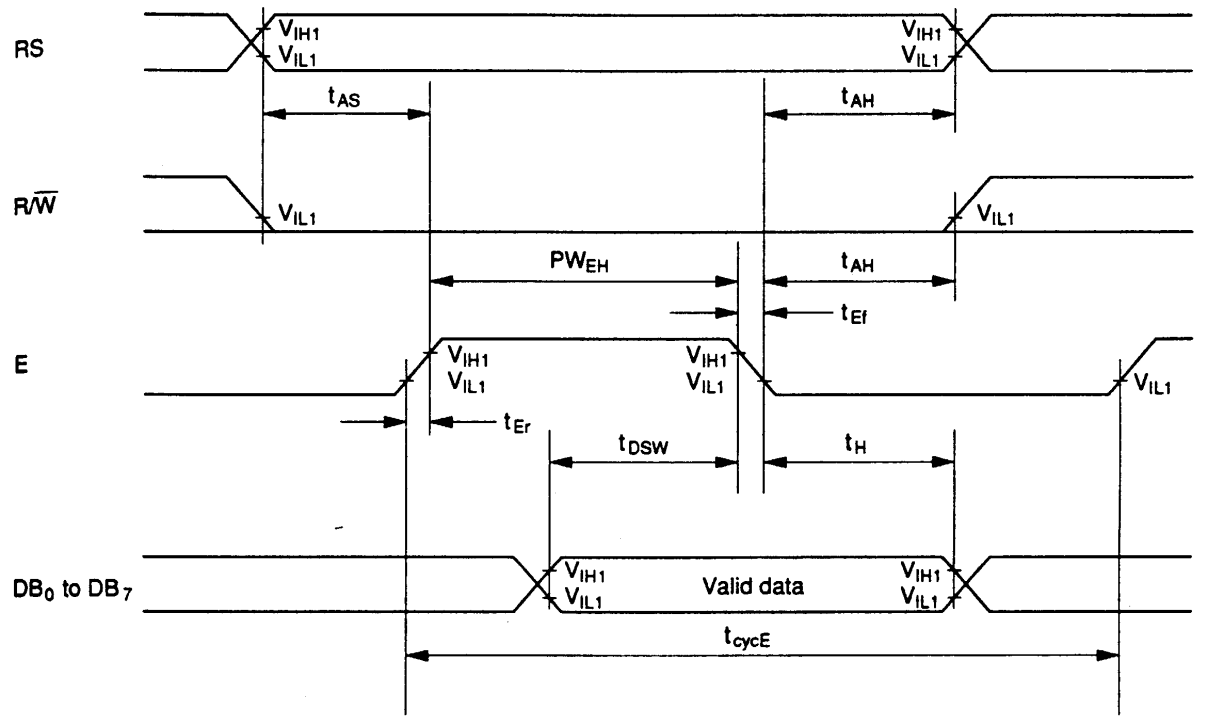

Item	Symbol	VDD=3.3V		Unit
		Min	Max	
Enable cycle time	t_{cycE}	1000	--	ns
Enable pulse width	PW_{EH}	450	--	
Enable rise/fall time	t_{Er}, t_{Erf}	--	25	
Address set-up time (RS, R/W to E)	t_{AS}	60	--	
Address hold time	t_{AH}	20	--	
Data set-up time	t_{DSW}	195	--	
Data hold time	t_H	10	--	

Read Operation

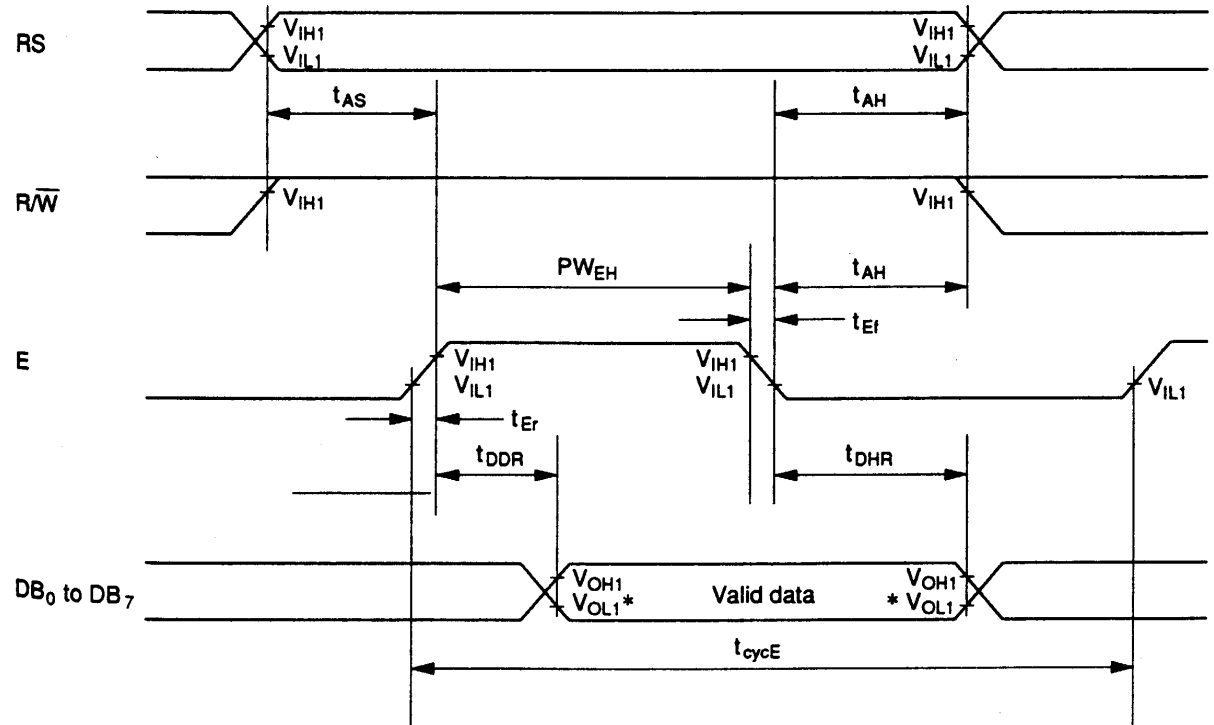

Item	Symbol	VDD=3.3V		Unit
		Min	Max	
Enable cycle time	t_{cycE}	1000	--	ns
Enable pulse width	P_{WEH}	450	--	
Enable rise/fall time	t_{Er}, t_{Ef}	--	25	
Address set-up time (RS, R/W to E)	t_{AS}	60	--	
Address hold time	t_{AH}	20	--	
Data delay time	t_{DDR}	--	360	
Data hold time	t_{DHR}	5	--	

8 INSTRUCTION SET

Instruction	Instruction Code										Description	Description Time (270KHz)
	RS	R/W	DB7	DB6	DB5	DB4	DB3	DB2	DB1	DB0		
Clear Display	0	0	0	0	0	0	0	0	0	1	Write "20H" to DDRAM. and set DDRAM address to "00H" from AC	1.52 ms
Return Home	0	0	0	0	0	0	0	0	1	x	Set DDRAM address to "00H" from AC and return cursor to its original position if shifted. The contents of DDRAM are not changed.	1.52 ms
Entry Mode Set	0	0	0	0	0	0	0	1	I/D	S	Sets cursor move direction and specifies display shift. These operations are performed during data write and read.	37 us
Display ON/OFF	0	0	0	0	0	0	1	D	C	B	D=1:entire display on C=1:cursor on B=1:cursor position on	37 us
Cursor or Display Shift	0	0	0	0	0	1	S/C	R/L	x	x	Set cursor moving and display shift control bit, and the direction, without changing DDRAM data.	37 us
Function Set	0	0	0	0	1	DL	N	F	x	x	DL:interface data is 8/4 bits N:number of line is 2/1 F:font size is 5x11/5x8	37 us
Set CGRAM address	0	0	0	1	AC5	AC4	AC3	AC2	AC1	AC0	Set CGRAM address in address counter	37 us
Set DDRAM address	0	0	1	AC6	AC5	AC4	AC3	AC2	AC1	AC0	Set DDRAM address in address counter	37 us
Read Busy flag and address	0	1	BF	AC6	AC5	AC4	AC3	AC2	AC1	AC0	Whether during internal operation or not can be known by reading BF. The contents of address counter can also be read.	0 us
Write data to RAM	1	0	D7	D6	D5	D4	D3	D2	D1	D0	Write data into internal RAM (DDRAM/CGRAM)	37 us
Read data from RAM	1	1	D7	D6	D5	D4	D3	D2	D1	D0	Read data from internal RAM (DDRAM/CGRAM)	37 us

Note:

Be sure the ST7066U is not in the busy state (BF = 0) before sending an instruction from the MPU to the ST7066U. If an instruction is sent without checking the busy flag, the time between the first instruction and next instruction will take much longer than the instruction time itself. Refer to Instruction Table for the list of each instruction execution time.

9 INITIALIZATION SEQUENCE

- 8-bit Interface (fosc=270KHz)

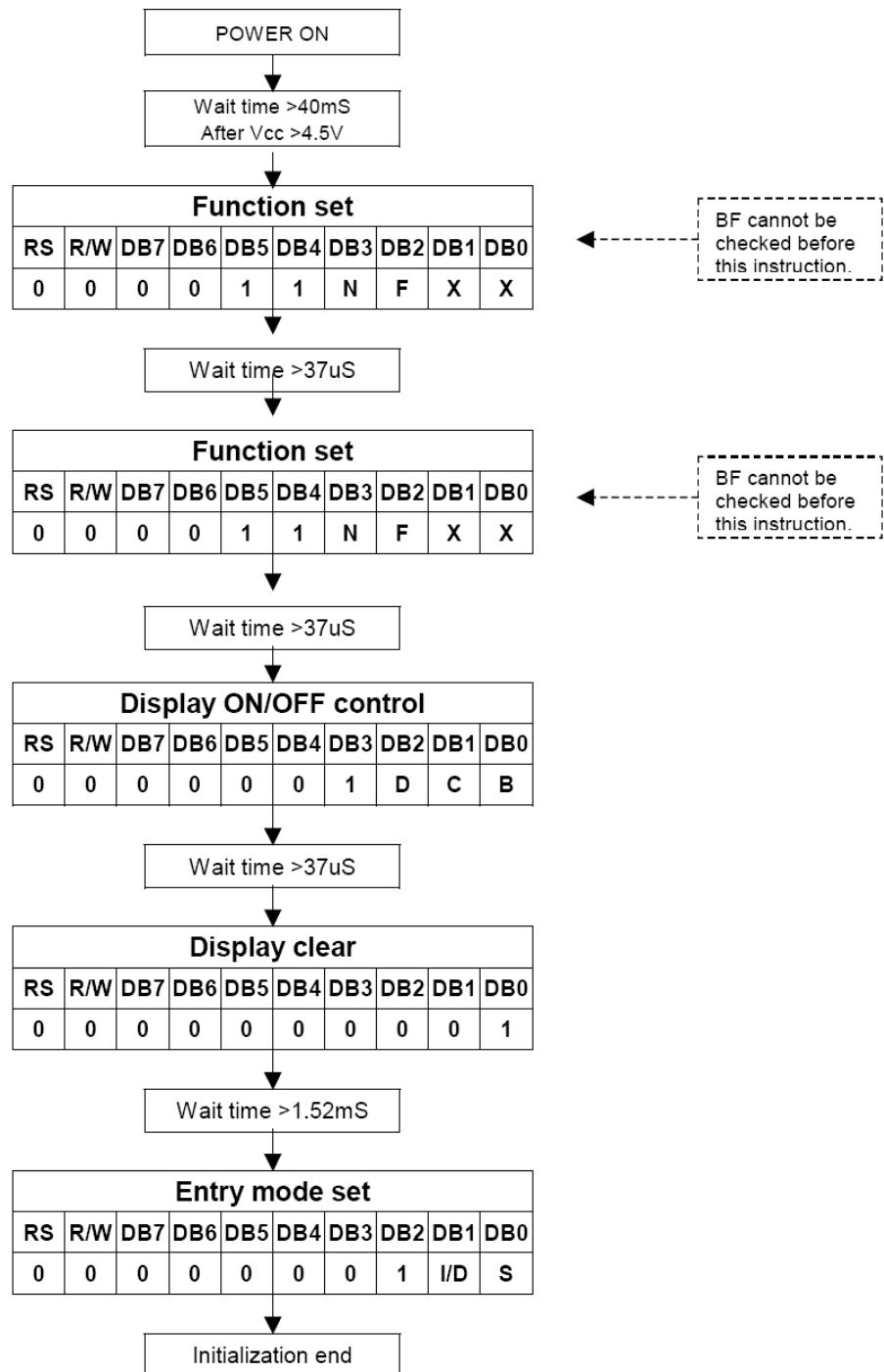

10 DD RAM ADDRESS

DIGIT	1	2	3	4	5	6	7	8	9	10	11	12	13	14	15	16
1 LINE	00	01	02	03	04	05	06	07	08	09	0A	0B	0C	0D	0E	0F
2 LINE	40	41	42	43	44	45	46	47	48	49	4A	4B	4C	4D	4E	4F

DD RAM Address

11 FONT TABLE

NO.7066-0A

b7-b4 b3-b0	0000	0001	0010	0011	0100	0101	0110	0111	1000	1001	1010	1011	1100	1101	1110	1111
0000	CG RAM (1)			0	a	P	^	P				-	3	E	o	p
0001	(2)	!	1	A	Q	a	q				.	7	*	G	ã	q
0010	(3)	"	2	B	R	b	r				r	4	U	X	B	o
0011	(4)	#	3	C	S	c	s				J	9	T	E	S	o
0100	(5)	\$	4	D	T	d	t				\	I	K	P	u	o
0101	(6)	%	5	E	U	e	u				.	7	*	I	o	U
0110	(7)	&	6	F	V	f	v				9	0	2	3	P	Z
0111	(8)	'	7	G	W	g	w				7	*	X	9	g	u
1000	(1)	<	8	H	X	h	x				4	9	*	U	r	X
1001	(2)	>	9	I	Y	i	y				o	7	J	U	'	U
1010	(3)	*	:	J	Z	j	z				E	0	n	V	j	#
1011	(4)	+	;	K	L	k	l				*	9	E	0	*	A
1100	(5)	,	<	L	#	l	l				o	9	7	7	o	A
1101	(6)	-	=	N	I	n	Y				u	X	\	U	t	-
1110	(7)	.	>	N	^	n	*				o	E	0	o	n	
1111	(8)	/	?	O	L	o	e				o	U	7	"	o	

12 QUALITY AND RELIABILITY

12.1 TEST CONDITIONS

Tests should be conducted under the following conditions:

Ambient temperature : $25 \pm 5^{\circ}\text{C}$

Humidity : $60 \pm 25\% \text{ RH}$.

12.2 SAMPLING PLAN

Sampling method shall be in accordance with MIL-STD-105E, inspection level II, normal inspection, and single sampling plan tables for normal, tightened, and reduced inspection.

12.3 ACCEPTABLE QUALITY LEVEL

A major defect is defined as one that could cause failure to or materially reduce the usability of the unit for its intended purpose. A minor defect is one that does not materially reduce the usability of the unit for its intended purpose or is an infringement from established standards and has no significant bearing on its effective use or operation.

12.4 APPEARANCE

An appearance test should be conducted by human sight at approximately 30 cm distance from the LCD module under fluorescent light. The inspection area of LCD panel shall be within the range of following limits.

12.5 INSPECTION QUALITY CRITERIA

ITEM	Description of defects			Class of defects	remark
Function	No display		Reject	Major	
	Display abnormal		Reject	Major	
	Missing line		Reject	Major	
Black spots	Ave. dia. D	Area A	Area B	Minor	Two spots must be between about 5 mm
	$D \leq 0.13$	Disregard			
	$0.13 < D \leq 0.15$	2	2		
	$0.13 < D \leq 0.25$	1	2		
	$0.25 < D$	0	1		
Black line	Width W	Length L	Area A	Area B	Minor
	≤ 3.0	≤ 0.02	Disregard		
	≤ 2.0	≤ 0.04	2	2	
	≤ 1.0	≤ 0.06	1	2	
		> 0.06	0	0	
Scratch	Width W		Length L	Accept	Minor
	$W \leq 0.02$		-----	Disregard	
	$0.02 \leq W \leq 0.05$		$L \leq 3.0$	2	
	$W > 0.05$		-----	0	
Appearance	PCB copper circuit showed		Reject	Minor	
	PCB scratch was over 5 mm		Reject		
	Sort pad was damaged		Reject		
★ Back-Light	Function didn't work		Reject	Major	
	Some area didn't work		Reject		
	Bright was not even		Reject		
	B/L color was not correct		Reject		
★ T/P (DOTS)	$D \leq 0.2\text{mm}$		Reject	Major	
	$0.2\text{mm} < D \leq 0.3\text{mm}$		Reject		
	$0.3\text{mm} < D$		Reject		
★ T/P (Scratch)	$W \leq 0.02\text{mm}$		$10\text{mm} < L$	Disregard	Major
	$0.05\text{mm} \leq W \leq 0.1\text{mm}$		$10\text{mm} < L$	1	
	$0.1\text{mm} \leq W$		$10\text{mm} < L$	0	

『★』 Symbol means LCM has this material.

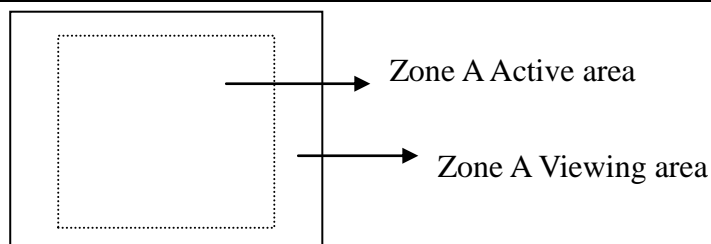

12.6 RELIABILITY

Test Item	Test Conditions	Note
	Normal Temp. type	
High Temperature Operation	50±3°C , t=96 hrs	
Low Temperature Operation	0±3°C , t=96 hrs	
High Temperature Storage	70±3°C , t=96 hrs	1,2
Low Temperature Storage	-20±3°C , t=96 hrs	1,2
Thermal Shock Test	-20°C ~ 25°C ~ 70°C 30 min. 5 min. 30 min. (1 cycle) Total 5 cycle	1,2
Humidity Test	40 °C, Humidity 90%, 96 hrs	1,2
Vibration Test (Packing)	Sweep frequency : 10 ~ 55 ~ 10 Hz/1min Amplitude : 0.75mm Test direction : X.Y.Z/3 axis Duration : 30min/each axis	2

Note 1 : Condensation of water is not permitted on the module.

Note 2 : The module should be inspected after 1 hour storage in normal conditions (15-35°C , 45-65%RH).

Definitions of life end point :

- Current drain should be smaller than the specific value.
- Function of the module should be maintained.
- Appearance and display quality should not have degraded noticeably.
- Contrast ratio should be greater than 50% of the initial value.

13 HANDLING PRECAUTIONS

- (1) A LCD module is a fragile item and should not be subjected to strong mechanical shocks.
- (2) Avoid applying pressure to the module surface. This will distort the glass and cause a change in color.
- (3) Under no circumstances should the position of the bezel tabs or their shape be modified.
- (4) Do not modify the display PCB in either shape or positioning of components.
- (5) Do not modify or move location of the zebra or heat seal connectors.
- (6) The device should only be soldered to during interfacing. Modification to other areas of the board should not be carried out.
- (7) In the event of LCD breakage and resultant leakage of fluid do not inhale, ingest or make contact with the skin. If contact is made rinse immediately.
- (8) When cleaning the module use a soft damp cloth with a mild solvent, such as Isopropyl or Ethyl alcohol. The use of water, ketone or aromatic is not permitted.
- (9) Prior to initial power up input signals should not be applied.
- (10) Protect the module against static electricity and observe appropriate anti-static precautions.
- (11) AMIPRE will provide one year warrantee for all products and three months warrantee for all repairing products.

14 OUTLINE DIMENSION

